

# CULINA CUL - 35865 Installation Instruction

## AYLA CCT

v2

Tools required:

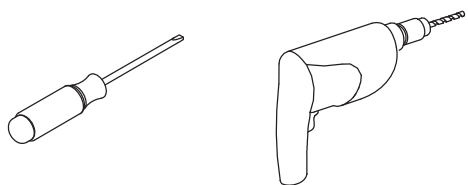

Parts supplied:

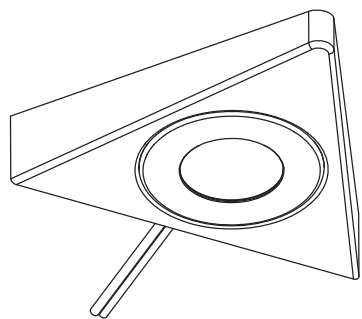

x 1



x 2

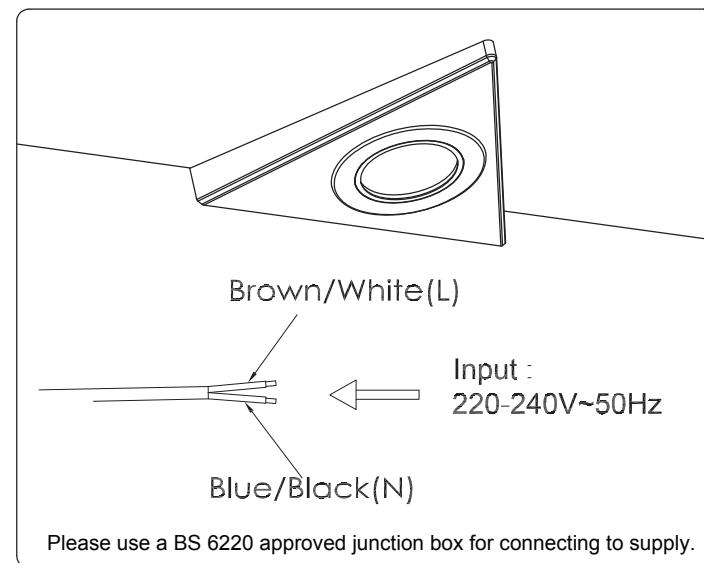
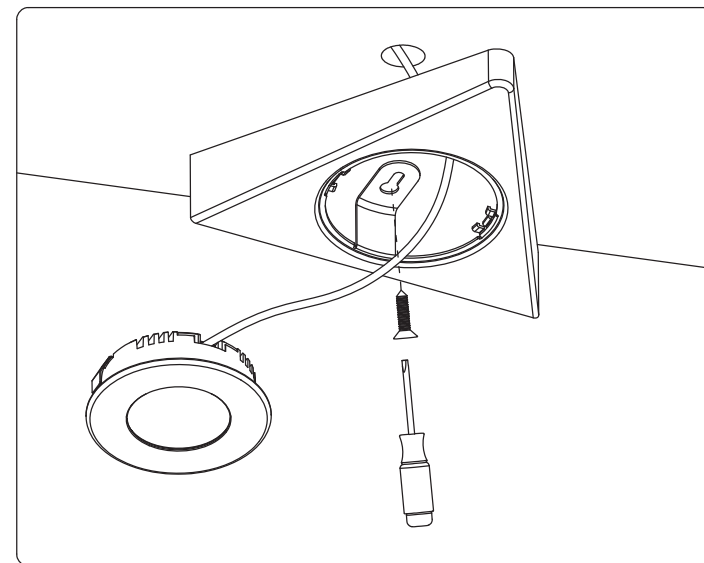
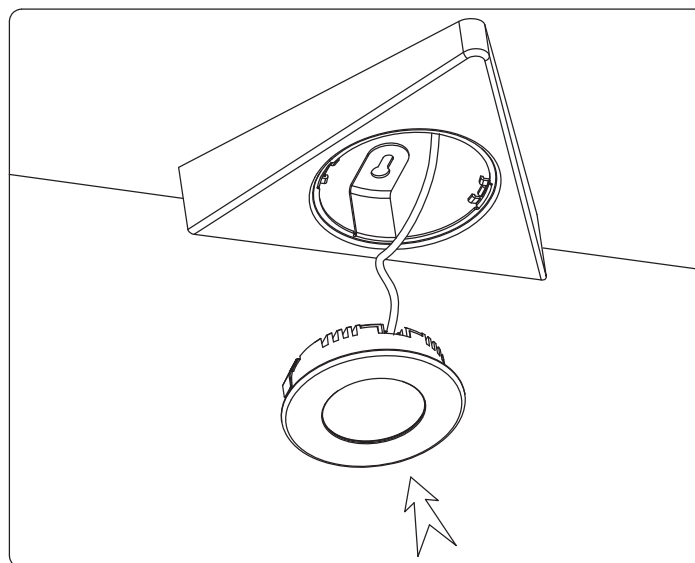
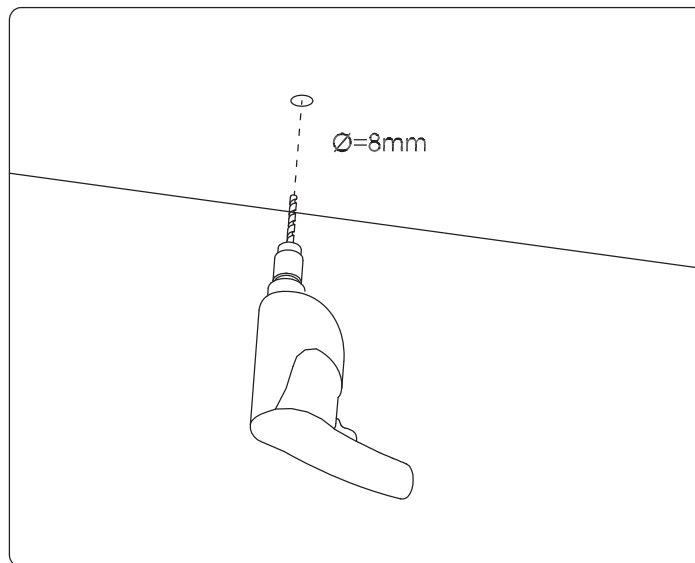

## Important Safety Information

All fittings should be connected via a 5 amp fused circuit and must be installed in accordance with current applicable building and electrical installation regulations. Before installation and servicing, disconnect the electrical supply at the mains. Carefully observe all instructions or warnings that are labelled on, or supplied with, your product. Unless otherwise stated, products are suitable for normal indoor use only and should not be used where water or high humidity may affect them.

**If in any doubt, consult a qualified electrician.**

## General Information

Do not mount ceiling/wall fittings onto damp surfaces such as newly painted or plastered areas as this may cause discolouration of the finish.

## Tools which may be required:

- Drill
- Cross Head Screwdriver
- Small Electrical Slotted Screwdriver
- Insulation Tape

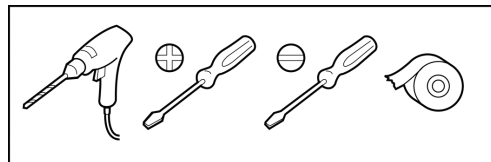

## Wiring the lamp

Refer to the diagrams below to ensure safe and correct connection to the mains supply.

For Double insulated items (Class 2): These are marked with the symbol

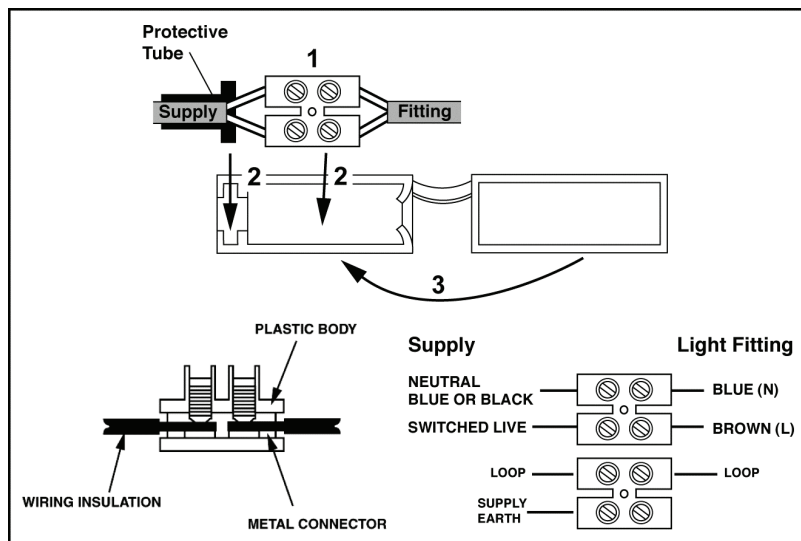

Please use a BS 6220 approved junction box for connecting to supply.

## Switch on!

You may now switch the electricity back on at the mains.

## Changing the colour temperature.

If you want to change the CCT:

Turn the light off by the wall switch (Not supplied), then turn it back on within 5 second, the CCT will be changed once.

If you don't want to change the CCT:

Wait for more than 6 seconds before turning on, the CCT will not be changed.

Reset mode: Reset to 3000K:

turn off-turn on 7 times within 10 second, the all lights will be reset to 3000K.

## Safety information

For your safety, please remember the following: Always switch off the supply before removing shades/covers, changing lightbulbs or cleaning.

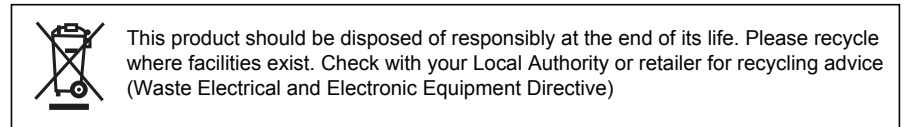

## Helpline

If you receive this item with parts broken or missing, please telephone:

**0333 0050077**

Please have ready your name, address, tel. no., product reference, where purchased and parts required. An answering service is in operation outside office hours and during busy periods.

**We regret that we are unable to give advice on internal house wiring.**

Cascade Holdings Ltd, Gorse Mill, Gorse Street, Chadderton, Oldham. OL9 9RJ