

JC50305

## Emergency Twin Spot Non-maintained IP65



### General Information

<b>Product Group</b>	Surface 3M Luminaire
<b>Product Range</b>	Emergency Range
<b>Product Weight</b>	1.7Kg
<b>Finishes Available</b>	White only
<b>Recommended Product Location</b>	Emergency Route/Exit Luminaire, Internal or external Use,
<b>Method Of Fix</b>	Screw Fix to Suitable Surface
<b>Max Angle Of Tilt &amp; Rotation</b>	110° tilt, 180° rotation
<b>Ingress Protection (IP)</b>	IP65
<b>Suitable For Zones</b>	Zone 1 & 2
<b>Luminaire Accessories</b>	None

#### JCC Lighting

Innovation Centre, Beeding Close, Southern Cross  
 Trading Estate, Bognor Regis, West Sussex, PO22 9TS  
 Company Registration Number: 03044848 | VAT Number: 918544112  
 T: 01243 838999 | F: 01243 838998 | [sales@jcc.co.uk](mailto:sales@jcc.co.uk) | [www.jcc.co.uk](http://www.jcc.co.uk)

## Electrical

<b>Input Voltage (V)</b>	220-240V~
<b>Primary Running Current</b>	230mA
<b>Operating Frequency (Hz)</b>	50/60Hz
<b>Luminaire Circuit Wattage</b>	3.4W(AC) 21.12W(DC)
<b>Class</b>	Class I, requires earth
<b>Output Voltage (V)</b>	9.6V
<b>Total Harmonic Distortion (THD)%</b>	TBC
<b>Power Factor Correction</b>	0.469
<b>Input Electrical Connections</b>	As per instruction sheet
<b>Dimmable</b>	No

## Emergency Data

<b>Load Voltage</b>	7.288 SELV
<b>Nominal Battery Current</b>	2200mAH
<b>Recharge Time</b>	24 Hours
<b>Battery Specification</b>	8 cell AA Type Ni-Cd 9.6V 2200mAh
<b>Battery Life In Emergency Mode</b>	3 hours
<b>DDP Protection</b>	Yes
<b>LOR In Emergency Mode</b>	100%
<b>Inverter PFC</b>	0.778

## Thermals

<b>Max Luminaire Ambient Temp.</b>	0° - 26°C
<b>Max Driver/Ballast Ambient Temp.</b>	40°C

### JCC Lighting

Innovation Centre, Beeding Close, Southern Cross  
Trading Estate, Bognor Regis, West Sussex, PO22 9TS  
Company Registration Number: 03044848 | VAT Number: 918544112  
T: 01243 838999 | F: 01243 838998 | [sales@jcc.co.uk](mailto:sales@jcc.co.uk) | [www.jcc.co.uk](http://www.jcc.co.uk)

## Performance Data

<b>Energy Rating</b>	A
<b>Lumen Output</b>	470lm (2 x 235) (DC)
<b>Lumens Per Circuit Watt</b>	22(DC) lm/W
<b>Lamp Life (Hours)</b>	30,000
<b>CRI: Ra</b>	48
<b>Colour Temperature (K)</b>	6000K
<b>LOR (Light Output Ratio) %</b>	100%
<b>Photometry Available</b>	TBC

## Construction

<b>Main Chassis</b>	Polycarbonate
<b>Diffuser</b>	Polycarbonate
<b>Rim Or Attachment</b>	Polycarbonate

## Packaging

<b>Luminaire Carton Dimensions</b>	285mm (L) x 285mm (W) x 95mm (D)
<b>Quantity Per Outer Carton</b>	5
<b>Bar Code EAN Number</b>	5052544047077
<b>Packaged Weight</b>	1.9Kg

## Standards & Approvals

<b>Manufactured In Accordance To</b>	BS EN 60598-2-22
<b>CE Marked</b>	Yes
<b>Batch Coded</b>	Yes
<b>Certificate Of Conformity</b>	Yes, available on request

### JCC Lighting

Innovation Centre, Beeding Close, Southern Cross  
Trading Estate, Bognor Regis, West Sussex, PO22 9TS  
Company Registration Number: 03044848 | VAT Number: 918544112  
T: 01243 838998 | F: 01243 838998 | [sales@jcc.co.uk](mailto:sales@jcc.co.uk) | [www.jcc.co.uk](http://www.jcc.co.uk)

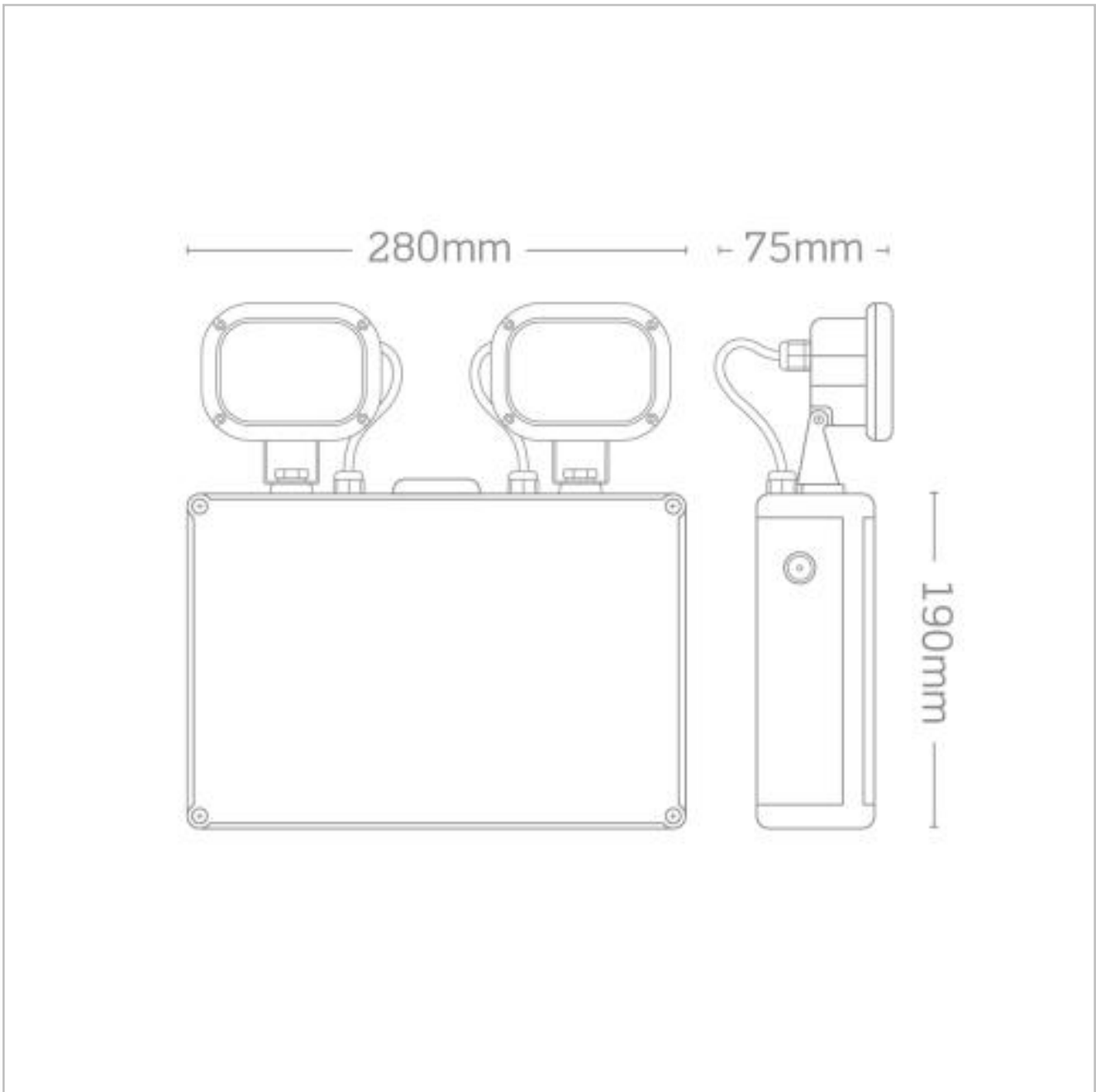

Datasheet generated from <http://www.electrika.cloud> on 12 February 2018 09:16:17

**JCC Lighting**

Innovation Centre, Beeding Close, Southern Cross  
Trading Estate, Bognor Regis, West Sussex, PO22 9TS  
Company Registration Number: 03044848 | VAT Number: 918544112  
T: 01243 838999 | F: 01243 838998 | [sales@jcc.co.uk](mailto:sales@jcc.co.uk) | [www.jcc.co.uk](http://www.jcc.co.uk)

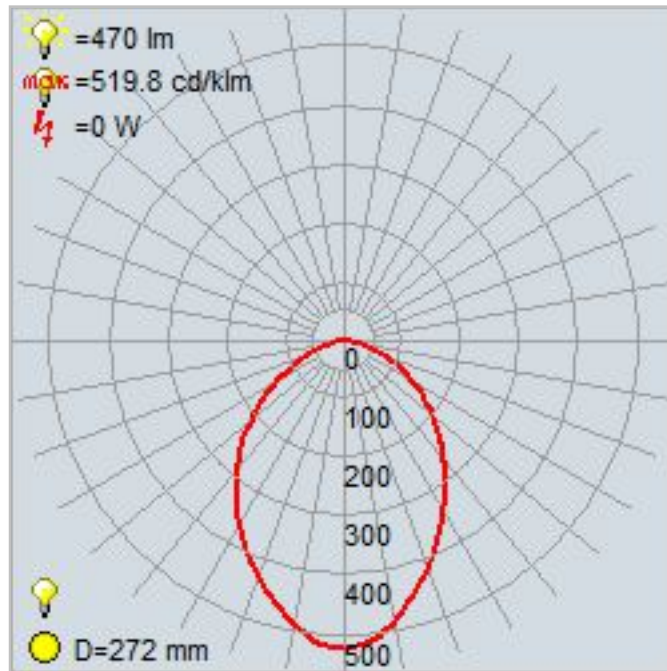

---

### JCC Lighting

Innovation Centre, Beeding Close, Southern Cross  
Trading Estate, Bognor Regis, West Sussex, PO22 9TS  
Company Registration Number: 03044848 | VAT Number: 918544112  
T: 01243 838999 | F: 01243 838998 | [sales@jcc.co.uk](mailto:sales@jcc.co.uk) | [www.jcc.co.uk](http://www.jcc.co.uk)